

UNDERCARRIAGE(HIGH WALKER, #0143-)

R210LC-7

ITEM 순번	PART NO 품 번	IS	DESCRIPTION 품 명	QTY 수량	SERIAL NO 적용 호기	ITC 호환	REMARK 비
*	@		UNDERCARRIAGE 언더캐리지	1	#0143-	-	
2	81EM-10012		SPROCKET 스프로킷	2			
4	81E1-19540		BOLT-SPROCKET 볼트	60	-#4443		
	81E1-19630		BOLT-SPROCKET 스프로킷 볼트	60	#4444-	B	
5	S017-200902		BOLT-HEX 육각 볼트	88	-#0340		
	S017-20090A		BOLT-HEX 육각 볼트	88	#0341-	A	
6	S441-200002		WASHER-HARDENED 고장력 와셔	88			
11	81EM-30510		TRACK GUARD WA-LH(A) 트랙 가드	2	-#0340		FU T/GUARD
	81N6-30510		TRACK GUARD WA(A)-LH 트랙 가드	2	#0341-#0453	D	FU T/GUARD
	81N6-30511		TRACK GUARD WA(A)-LH 트랙 가드	2	#0454-	A	FU T/GUARD
12	81EM-30520		TRACK GUARD WA-LH(B) 트랙 가드	2	-#0340		FU T/GUARD
	81N6-30520		TRACK GUARD WA(A)-RH 트랙 가드	2	#0341-#0453	D	FU T/GUARD
	81N6-30521		TRACK GUARD WA(A)-RH 트랙 가드	2	#0454-	A	FU T/GUARD
13	81EM-30530		TRACK GUARD WA-RH(A) 트랙 가드	2	-#0340		FU T/GUARD
	81N6-30530		TRACK GUARD WA(B)-LH 트랙 가드	2	#0341-#0453	D	FU T/GUARD
	81N6-30531		TRACK GUARD WA(B)-LH 트랙 가드	2	#0454-	A	FU T/GUARD
14	81EM-30540		TRACK GUARD WA-RH(B) 트랙 가드	2	-#0340		FU T/GUARD
	81N6-30540		TRACK GUARD WA(B)-RH 트랙 가드	2	#0341-#0453	D	FU T/GUARD
	81N6-30541		TRACK GUARD WA(B)-RH 트랙 가드	2	#0454-	A	FU T/GUARD
15	81EM-30960		SPACER 스페이서	12			
16	81EM-30970		BOLT-STUD 볼트	12	-#0453		
	S017-243202		BOLT-HEX 육각 볼트	12	#0454-	D	
17	S017-240452		BOLT-HEX육각 볼트	32			
18	S207-241002		NUT-HEX 육각 너트	24	-#0453		MEMO T/GUARD
	S207-241002		NUT-HEX 육각 너트	12	#0454-	A	
19	S403-242002		WASHER-PLAIN 평 와셔	24	-#0453		
	S441-240002		WASHER-HARDENED 고장력 와셔	56	#0454-	A	
20	S411-240002		WASHER-SPRING 스프링 와셔	24	-#0340		
	S411-240002		WASHER-SPRING 스프링 와셔	56	#0341-#0453	-	
21	S441-240002		WASHER-HARDENED 고장력 와셔	32	-#0340	-	MEMO T/GUARD
30	81EM-30750		GUARD-TRACK WA 트랙 가드	4			MEMO T/GUARD

2006. 5.31 REV.6E

5011

ITEM 순번	PART NO 품 번	IS	DESCRIPTION 품 명	QTY 수량	SERIAL NO 적용 호기	ITC 호환	REMARK 비 고
•	81N6-13010		IDLER ASSY	1			
1	81N6-13101		• SHELL-IDLER	1	#0001 -		
2	81N6-13110		• SHAFT	1			
3	81N6-13140		• SEAL ASSY	2			
4	81N6-13120		• BUSHING	2			EE-0836
5	81N6-13131		• BRACKET-IDLER	2	#0001 -		
6	S632-070001		• O-RING	2			
7	81N6-13180		• PIN-SPRING	2			
8	P220-430202		• PLUG	1			

IDLER

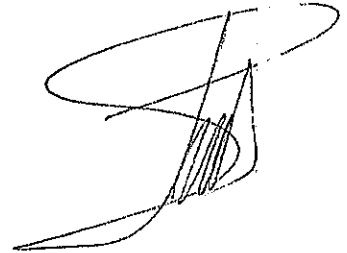
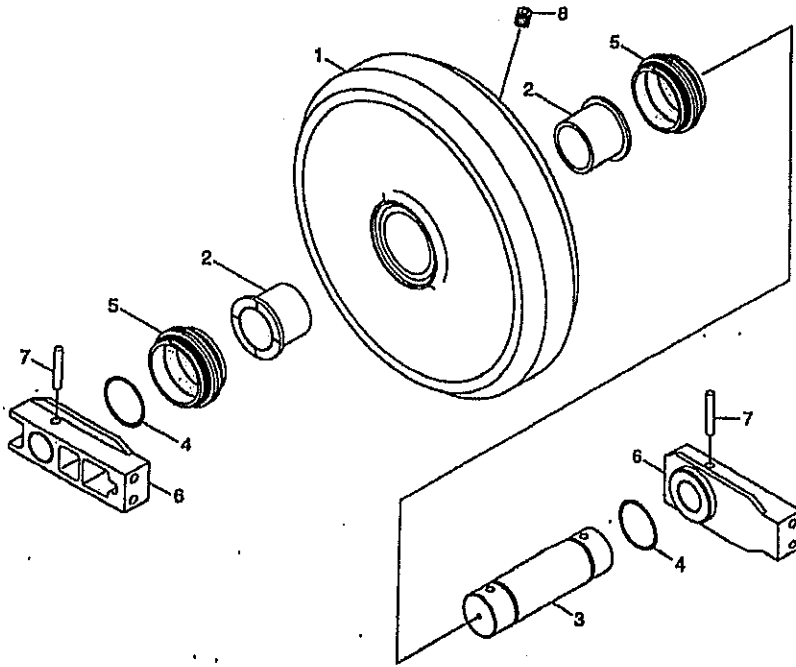

ITEM 순번	PART NO 품 번	IS	DESCRIPTION 품 명	QTY 수량	SERIAL NO 적용 호기	ITC 호환	REMARK 비 고
•	E181-2002	40	LOWER ROLLER ASSY	하부 롤러	1		
1	E181-22010		• ROLLER WA	롤러	1		
2	E181-2205	20	• SHAFT	샤프트	1		
3	E181-22070		• COLLAR	칼라	2		
4	E181-2202	20	• BUSHING	부싱	2		
5	E181-2206	20	• PIN-SPRING	스프링 핀	2		
6	E181-22030		• SEAL ASSY	씰	2		
N6-1	E181-22000		•• SEAL	씰	4		
N6-2	E181-22090		•• O-RING	O-링	4		
7	E181-2204	20	• O-RING	O-링	2		
8	E282-2407	20	• PLUG	플러그	1		
N	Ⓢ		NOT INDIVIDUALLY SUPPLIED 단품공급불가				

LOWER ROLLER

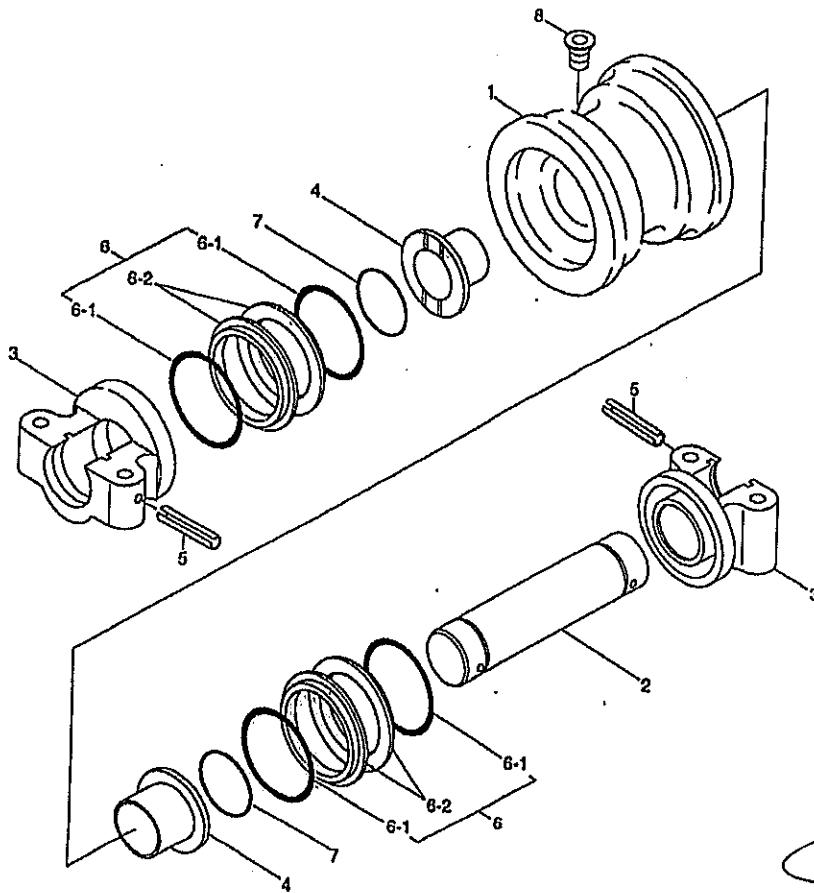

UNDERCARRIAGE(HIGH WALKER, #0143-)

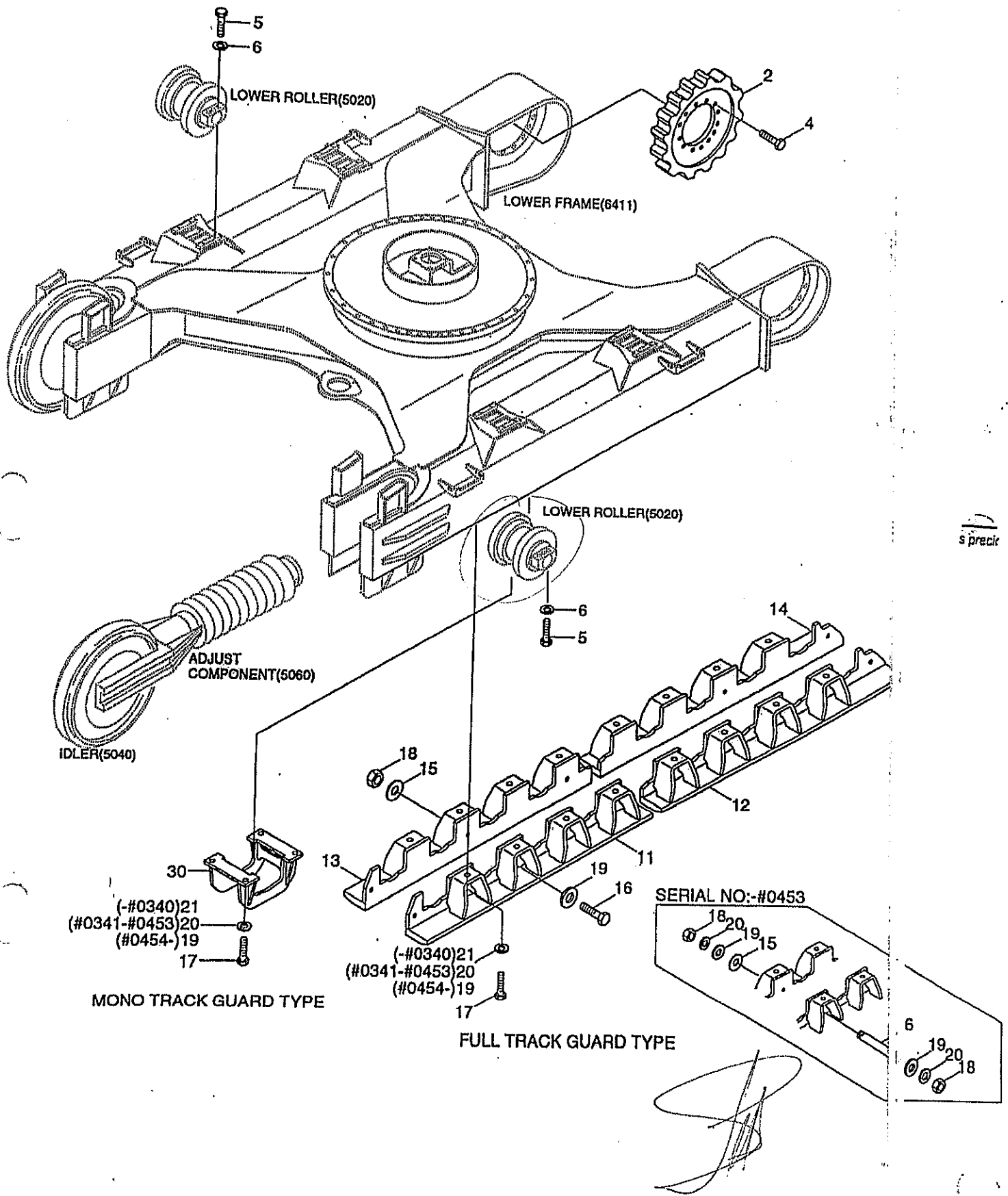

s precir

5011

2006.5.31 REV.6E

TRACK CHAIN

ITEM 순번	PART NO 품 번	IS	DESCRIPTION 품 명	QTY 수량	SERIAL NO 적용 호기	ITC 호환	REMARK 비 고
*	81N6-26030		TRACK CHAIN ASSY	1	#0001 -	-	10mm, INI
	81N6-24030		TRACK CHAIN ASSY	1	#1387 -	-	10mm, DCF
1	81N6-26600		• TRACK LINK ASSY	1			
1-1	81N6-26100		•• TRACK LINK-RH	49			
1-2	81N6-26110		•• TRACK LINK-LH	49			
1-3	81N6-26140		•• PIN-TRACK	48			
1-4	81N6-26160		•• PIN-MASTER	1			
1-5	81N6-26150		•• BUSHING-TRACK	48			
1-6	81N6-26170		•• BUSHING-MASTER	1			
1-7	81N6-26210		•• SEAL-DUST	96			
1-8	81N6-26180		•• SPACER	2			
*-1	81EM-T0000		• TRACK BOLT & NUT KIT	196	#0001 -	-	
2	81EM-20020		•• BOLT-SHOE	1			
3	81N6-26620		•• NUT	1			
4	81EM-28030		• SHOE-TRACK	49	-#0413		10mm, INI
	81EM-28031		• SHOE-TRACK	49	#0414-	B	10mm, INI
	81N6-25530		• SHOE-TRACK	49	#1387-#2747	-	10mm, DCF
	81N6-26040		TRACK CHAIN ASSY	1			10mm, INI
	81N6-24040		TRACK CHAIN ASSY	1	#1387 -	-	10mm, DCF
5	81EM-28040		• SHOE-TRACK	49			10mm, INI
	81N6-25540		• SHOE-TRACK	49	#1387-#2747	-	10mm, DCF
*	81N6-26060		TRACK CHAIN ASSY	1			10mm, INI
*	81N6-24060		TRACK CHAIN ASSY	1	#1387 -	-	10mm, DCF
6	81EM-28060		• SHOE-TRACK	49			10mm, INI
	81N6-25560		• SHOE-TRACK	49	#1387-#2747	-	10mm, DCF
*	81N6-26070		TRACK CHAIN ASSY	1			10mm, INI
7	81EM-28070		• SHOE-TRACK	49			10mm, INI
*	81N6-26080		TRACK CHAIN ASSY	1	#1659 -	-	10mm, DCF
*-1	81EM-T0000		• TRACK BOLT & NUT KIT	196	#1659 -	-	
12	81EM-20040		•• BOLT-SHOE	1	#1659 -	-	10mm, DCF
13	81N6-26620		•• NUT	1	#1659 -	-	10mm, DCF
8	81EM-28080		• SHOE-TRACK	49	#1659 -	-	10mm, DCF

TF

TRACK CHAIN

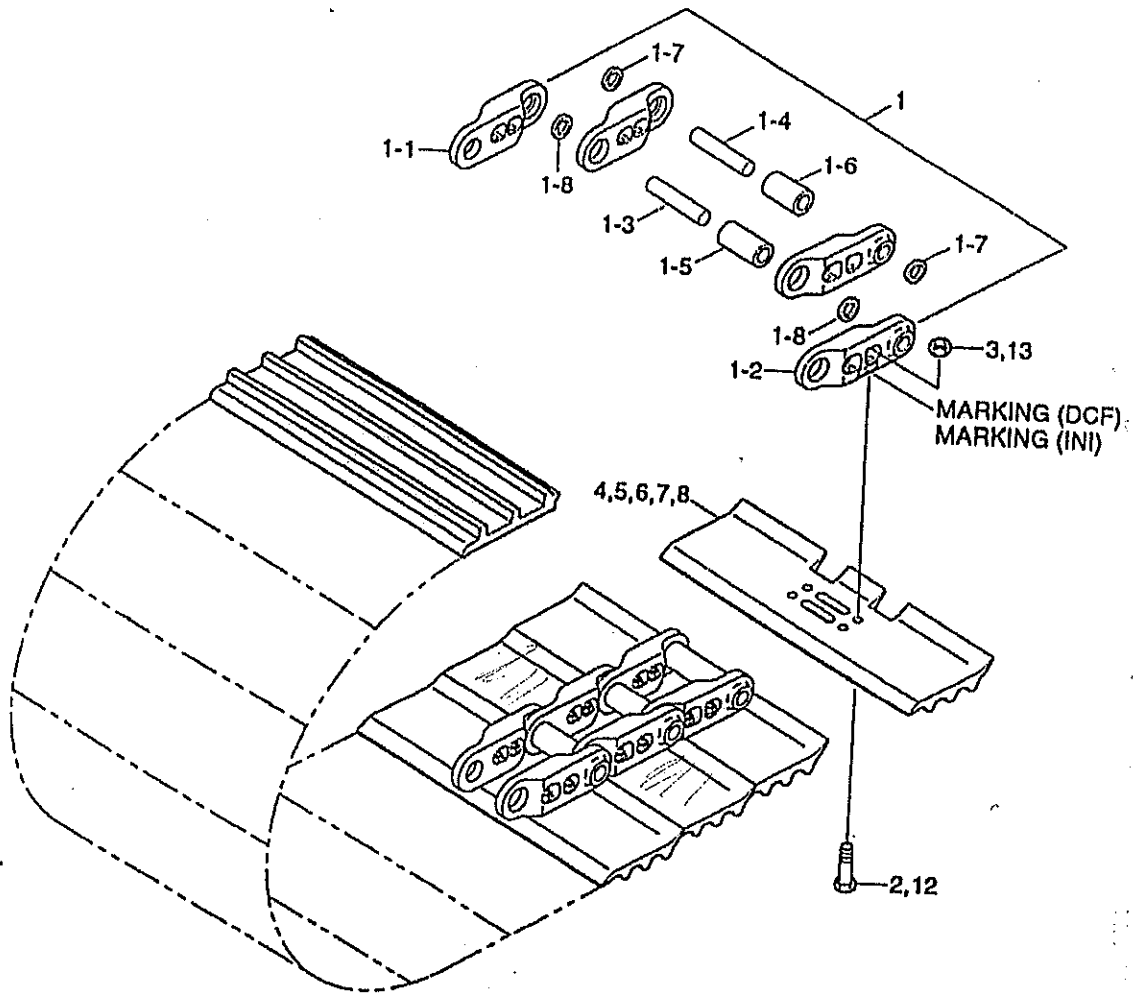

5050

2006. 3.31 REV.6C